

1. MAINTENANCE

Properly maintained, the MODEL FM-2024 desoldering tool should provide years of good service. Efficient desoldering depends upon the temperature, and the quality and quantity of the solder and flux. Perform the following service procedures as dictated by the conditions of the gun's usage.

⚠ WARNING

Since the desoldering tool can reach a very high temperature, please work carefully. Except when cleaning the nozzle and heating element, ALWAYS turn the power switch OFF and disconnect the power plug before performing any maintenance procedure.

Maintenance of nozzle

⚠ CAUTION

The desoldering tool may be extremely hot. During maintenance, please work carefully.

Inspect and clean the nozzle.

- Plug in the power cord, turn the power switch ON and let the nozzle heat up.

⚠ CAUTION

The cleaning pin will not pass through the nozzle until the solder inside the nozzle is completely melted.

- Clean out the hole of the nozzle with the nozzle cleaning pin (not included as a standard accessories).
- If the cleaning pin does not pass through the hole in the nozzle, clean with the cleaning drill. (not included as a standard accessories).
- Check the condition of the solder plating on the nozzle tip.
- Check visually if the nozzle was eroded.

⚠ CAUTION

The inside hole and the surface of the nozzle is plated with a special alloy. Should this alloy become eroded by high-temperature solder, the nozzle will not be able to maintain the proper temperature.

- If the nozzle is still in a good condition, put some fresh solder on the nozzle tip to protect solder plated area from oxidation.

Cleaning with the nozzle cleaning pin

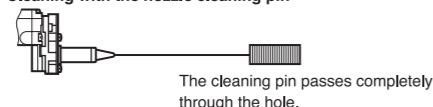

Cleaning with the cleaning drill

- Before cleaning

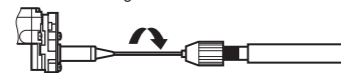

- After cleaning

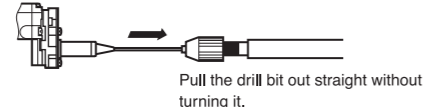

⚠ CAUTION

If the cleaning drill is forced into the nozzle, the drill bit could break or be damaged. Please use the proper size cleaning pin or cleaning drill for the nozzle diameter.

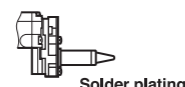

- If the cleaning pin and cleaning drill does not pass through the hole in the nozzle, replace the nozzle.
- If the solder plating on the nozzle tip is worn, replace the nozzle.
- If the inside hole of the nozzle is eroded, replace the nozzle.

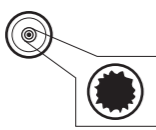

⚠ CAUTION

Unfortunately, it is often difficult to observe this condition. Therefore, if desoldering efficiency goes down and all other parts appear to be OK, the nozzle is probably eroded and should be replaced.

※ 各言語（日本語、英語、中国語、フランス語、ドイツ語、韓国語）の取扱説明書は以下のURL、HAKKO Document Portalからダウンロードしてご覧いただけます。

（商品によっては設定の無い言語がありますが、ご了承ください）
* 各言語（日本語、英語、中文、法語、ドイツ語、韓国語）の使用説明書は以下のURL、HAKKO Document Portal からダウンロード。（一部の製品は設定外語対応、請見読）

* Instruction manual for the language, Japanese, English, Chinese, French, German and Korean can be downloaded from the following URL, HAKKO Document Portal. (Please note that some language may not be available depending on the product.)

<https://doc.hakko.com>

1. MAINTENANCE

Cleaning the inside of suction pipe

Move the nozzle cartridge to the cleaning position indicated in figure at right. Change the position of the nozzle cartridge before turning the power ON, to prevent accidents.

To clean the inside of the suction pipe, ensure that the solder remaining in the pipe has been completely melted.

For the cleaning of the suction pipe, set the nozzle temperature to 400°C/750°F or higher. Start this cleaning after the set temperature has been reached.

To clean the inside of the suction pipe, insert the cleaning drill fully into the suction pipe while turning it clockwise. Then remove the accumulated debris.

Check and clean the front and back holder bushings

If foreign matter gets stuck on the contact surface between the front holder and the filter pipe assembly, or between the back rubber holder bushing and the filter pipe assembly, air will be sucked into the tool, preventing normal desoldering. Remove the solder and flux adhering to the surface of front holder (A) and back holder (B) then connect the filter pipe assembly.

● Checking procedure

■ Checking the cord assembly

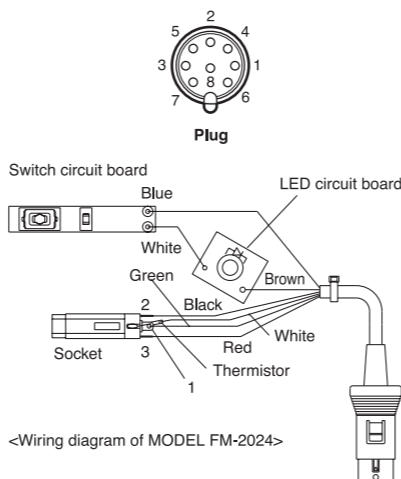

<Wiring diagram of MODEL FM-2024>

■ Checking the grounding line

■ Checking the heater/sensor

NOTE:

Once removing the nozzle from the grip while pressing the nozzle unlock button, then insert the nozzle as the following position.

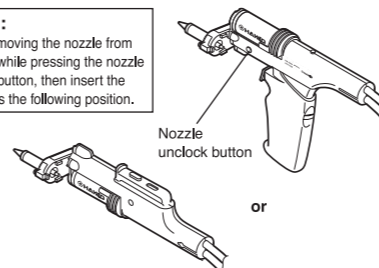

⚠ CAUTION

If you insert the drill without turning it or if you try to insert the drill at an angle, the nozzle cartridge may be broken.

⚠ CAUTION

Remove the cleaning drill on axis with the nozzle. If it is difficult to remove the drill, turn it slightly whilst withdrawing it. If you forcibly remove the drill, the cartridge may be broken.

⚠ WARNING

Unless otherwise specified, perform the following steps after turning the power switch OFF and disconnecting the AC plug.

Checking the electrical continuity of the cord assembly

1. Remove the plug of the cord assembly from the station.
2. If the handle is attached, remove it.
3. Remove the nozzle cartridge. For this removal, see "Attaching and replacing the nozzle cartridge."
4. Remove the screws for the grip and measure the resistance between the socket terminal and the connector pin as shown below (refer to the wiring diagram).

Plug 1	Red (socket) 3
Plug 2	Green (socket) 1
Plug 3	Black (socket) 2
Plug 4	Brown (LED circuit board)
Plug 5	White (thermistor)
Plug 6	Blue (switch circuit board)

If the resistance is larger than 0Ω or ∞ in any location, replace the cord assembly.

1. Measure the resistance between plug pin 2 and the nozzle end.
2. If the resistance value exceeds 2Ω (at room temperature), perform the maintenance for the nozzle, which is described in page 72 of the instruction manual for the HAKKO FM-203. If this does not decrease the value, check the electrical continuity of the cord assembly.

Checking for electrical continuity of heater/sensor

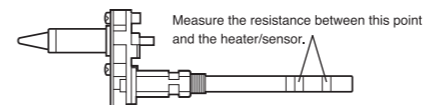

Measure the resistance at room temperature (15 to 25°C ; 59 to 77°F). The normal range is 8Ω ± 10%. If the resistance is outside this range, replace the nozzle assembly.

1. MAINTENANCE

Checking and replacing the ceramic paper filter (DCB)

1. Turn the filter case cover on the DCB clockwise to unlock it, then remove the cover by pulling it straight out.

DCB

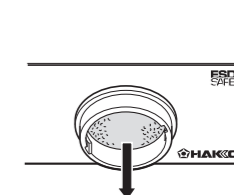
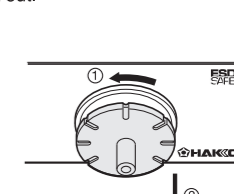

The filter is clogged with hardened flux.

Replace the ceramic paper filter.

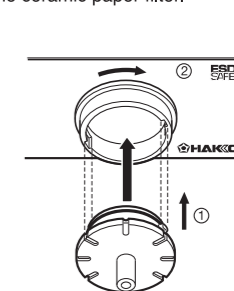

Fit the filter case cover in place.

After replacing the ceramic paper filter, press the filter case cover with its tabs inserted into the corresponding slots in the filter case then turn clockwise to lock it.

2. TROUBLE SHOOTING GUIDE

⚠ WARNING

- To check inside or replace parts, be sure to turn the power switch OFF and remove the AC plug to avoid electric shock.

- No operation occurs when the power switch is turned ON.

CHECK : Is the power cord connected properly (Soldering station and/or DCB)?
ACTION : Properly connect the power cable.
CHECK : Is the fuse blown out?
ACTION : After identifying the cause (e.g., short-circuit in the desoldering iron), replace the fuse.

- When the power switch is turned ON. Soldering iron error is displayed.

- HAKKO FM-203 shows [E-E].

CHECK : Is MODEL FM-2024 connected?
ACTION : Connect MODEL FM-2024.
CHECK : Is the cord assembly connected properly?
ACTION : Connect again while referring to "Preparation - Assembling and Connections."
CHECK : Is the cord assembly broken?
ACTION : Refer to "Checking for electrical discontinuity of the cord assembly" in Maintenance.

- The nozzle is not heated. Sensor error is displayed.

- HAKKO FM-203 shows [S-E].

CHECK : Is the nozzle cartridge fully inserted?
ACTION : Fully insert the nozzle cartridge.
CHECK : Is the cord assembly broken? Is the heater/sensor disconnected?
ACTION : Refer to "Checking for electrical continuity of cord assembly" and "Checking for electrical continuity of heater/sensor" in Maintenance.

- The nozzle end does not extract solder.

CHECK : Is the set temperature for the nozzle too high?
ACTION : Set the nozzle temperature at the appropriate level.
CHECK : Is the nozzle end plugged or coated with oxide?
ACTION : Remove the oxide by cleaning the nozzle end.
CHECK : Has the nozzle end deteriorated due to corrosion?
ACTION : Replace the nozzle.

2. TROUBLE SHOOTING GUIDE

● The nozzle temperature is too high.

● The nozzle temperature is too low.

● **H-E** Error indicating low temperature alarm setting occurs frequently.

● **HSE** is displayed indicating heater terminal short-circuit error.

● The solder cannot be removed.

● The suction power has decreased.

CHECK : Is the cord assembly broken?
ACTION : Refer to "Checking for electrical continuity of connecting cable" in Maintenance.

CHECK : Is any oxide adhered to the nozzle end?
ACTION : Remove the oxide by cleaning the nozzle end with HAKKO 599B Tip cleaner.

CHECK : Has the nozzle end deteriorated due to corrosion?
ACTION : Replace the nozzle.

CHECK : Is the setting for the low temperature alarm too low?
ACTION : Increase the setting.

CHECK : Is the nozzle cartridge for use with MODEL FM-2024?
ACTION : Turn the power switch OFF, press-fit the nozzle for the MODEL FM-2024, then turn the power switch ON.

CHECK : Is the heating value insufficient?
ACTION : In cases where the piece to be desoldered is large, HAKKO recommends the use of a pre-heater to preclude the possibility of damage to the board or components that might occur as a result of excessively high nozzle temperatures.

CHECK : Is it difficult to get solder on the nozzle?
ACTION : Refer to "Maintenance of nozzle".

CHECK : Is the inside of the nozzle or suction pipe clogged?
ACTION : Refer to "Maintenance of nozzle" and "Cleaning the inside of suction pipe."

CHECK : Is the filter pipe full of extracted solder?
ACTION : If the filter pipe is 70 - 80% full of solder, replace the filter pipe assembly. If the ceramic paper filter is stiff with absorbed flux, replace the filter pipe assembly.

CHECK : Is solder residue stuck on the contact surface between the front holder or the back holder bushing and the filter pipe assembly?
ACTION : Refer to "Checking and cleaning front and back holder bushings."

CHECK : Has the ceramic paper filter (DCB) deteriorated?
ACTION : The ceramic paper filter (DCB) is full of flux, causing a loss of suction. Refer to "Checking and replacing the ceramic paper filter (DCB)."

3. PARTS LIST

Desolder control box

Item No	Part No.	Part Name	Specifications
①	C1526	Desolder control box/100V	With power cord, 3 wired cord & American plug
	C1497	Desolder control box/110V	With power cord, 3 wired cord & American plug
	C1498	Desolder control box/220V	With power cord, 3 wired cord & American plug
	C1499	Desolder control box/220V	With power cord, 3 wired cord but no plug
	C1500	Desolder control box/220V	With power cord, 3 wired cord & Chinese plug
	C1501	Desolder control box/230-240V	With power cord, 3 wired cord & Australian plug
	C1502	Desolder control box/230V	With power cord, 3 wired cord but no plug
	C1503	Desolder control box/230V	With power cord, 3 wired cord & BS plug
	C1528	Desolder control box/230V	With power cord, 3 wired cord & European plug CE
	C1529	Desolder control box/230V	With power cord, 3 wired cord & BS plug CE
	C1530	Desolder control box/220V	With power cord, 3 wired cord & European plug

②	A1613	Ceramic paper filter	Set of 10
③	B2880	Vacuum outlet cap	With o-ring
	B2068	Power cord, 3 wired cord & American plug	For U.S.A.
	B2079	Power cord, 3 wired cord but no plug	
	B2081	Power cord, 3 wired cord & Australian plug	
	B2082	Power cord, 3 wired cord & BS plug	India
	B2490	Power cord, 3 wired cord & Chinese plug	
	B3053	Power cord, 3 wired cord & European plug	CE, KTL
	B3054	Power cord, 3 wired cord & BS plug	CE
	B3505	Power cord, 3 wired cord & American plug	

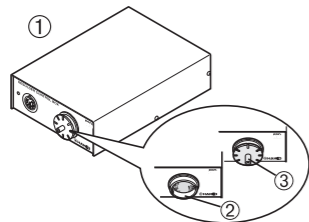

3. PARTS LIST

Iron Holder

Item No.	Part No.	Part Name	Specifications
①	B3251	Iron holder base	with rubber feet
②	B3249	Cleaner base	with rubber feet
③	A1519	Cleaning sponge	Yellow
④	B3413	Iron holder assembly	With screws
⑤	B3250	Stay	
⑥	B3252	Switch case assembly	
⑦	599B-02	Tip cleaner	
⑧	599-029	Cleaning wire	
⑨	B3253	Connecting cable	

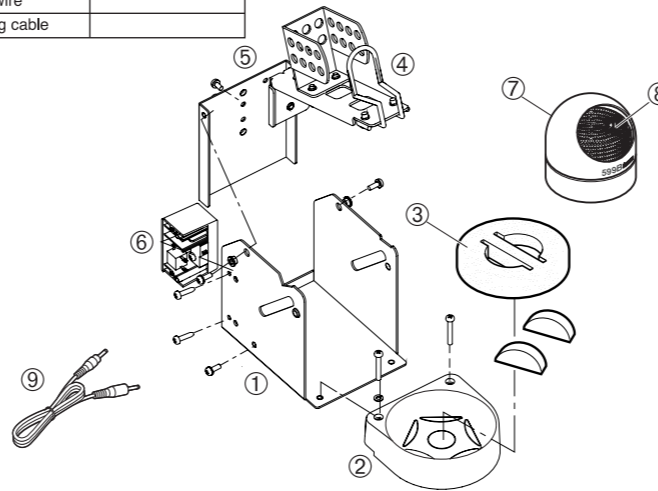

Nozzle

Part No.	Part Name	oA	oB
N1-06	Nozzle, 0.6 mm	0.6 mm	1.9 mm
N1-08	Nozzle, 0.8 mm	0.8 mm	2.0 mm
N1-10	Nozzle, 1.0 mm	1.0 mm	2.2 mm
N1-13	Nozzle, 1.3 mm	1.3 mm	2.6 mm
N1-16	Nozzle, 1.6 mm	1.6 mm	3.0 mm
N1-20	Nozzle, 2.0 mm	2.0 mm	3.4 mm
N1-23	Nozzle, 2.3 mm	2.3 mm	3.8 mm

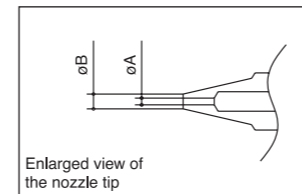

Part No.	Part Name	oA	oB
N1-L10	Long nozzle, 1.0 mm	1.0 mm	2.3 mm

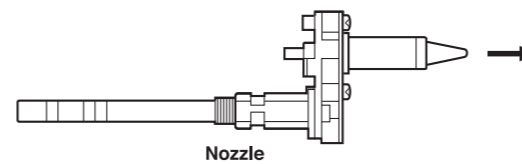
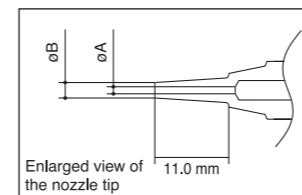

Desoldering tool

Item No.	Part No.	Part Name	Specifications
	FM2024-22	Conversion kit/100V	DCB:C1495 *1
	FM2024-23	Conversion kit/110V	DCB:C1497 *2
	FM2024-24	Conversion kit/110V	DCB:C1497 *2
	FM2024-25	Conversion kit/220V	DCB:C1498 *2
	FM2024-26	Conversion kit/220V	DCB:C1499 *2
	FM2024-27	Conversion kit/220V	DCB:C1500 *2
	FM2024-28	Conversion kit/230-240V	DCB:C1502 *2
	FM2024-29	Conversion kit/230V	DCB:C1502 *2
	FM2024-30	Conversion kit/230V	DCB:C1503 *2
	FM2024-31	Conversion kit/220V	DCB:C1530 *2
	FM2024-32	Conversion kit/100V	DCB:C1526 *2
	FM2024-33	Conversion kit/230V	DCB:C1528 *2
	FM2024-34	Conversion kit/230V	DCB:C1528 *2
	FM2024-35	Conversion kit/230V	DCB:C1529 *2
	FM2024-36	Conversion kit/230-240V	DCB:C1501 *2
	FM2024-37	Conversion kit/220V	DCB:C1499 *2

①-⑥, ⑧	FM2024-02	Desoldering tool	24V, 70W
①	A1512	Front holder	
②	A1612	Filter pipe assembly	Set of 10
③	A1513	Back holder bushing	
④	B2878	Back holder	
⑤	B2877	Hose	
⑥	B2879	Flange	
⑦		Nozzle	See parts list for nozzle
⑧	B2872	Handle	For gun configuration
⑨	B2873	Cleaning drill	For heating element
⑩	B2876	Nozzle remover	

*1 With a sleep mode iron holder, cleaning sponge (FH200-06)

*2 With a sleep mode iron holder, 599B (FH200-05)

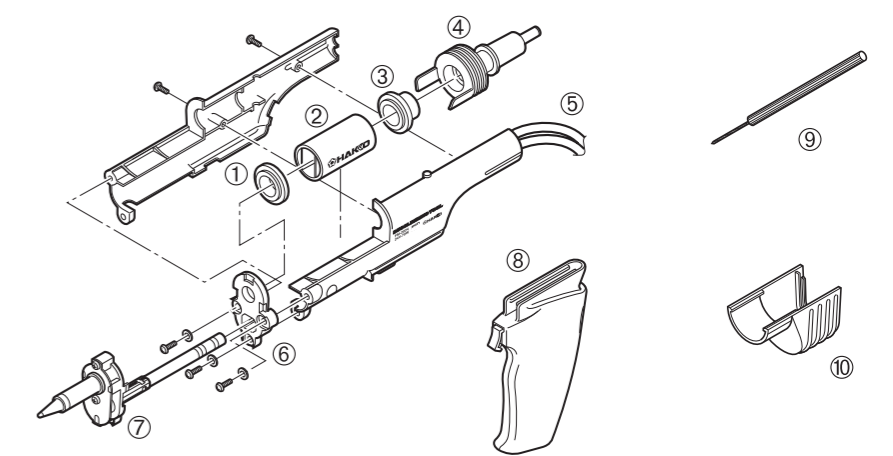

3. PARTS LIST

Desoldering tool

Item No.	Part No.	Part Name	Specifications
①	B2874	Cleaning pin	For ø0.6 mm nozzle
	B1086	Cleaning pin	For ø0.8 mm nozzle
	B1087	Cleaning pin	For ø1.0 mm nozzle
	B1088	Cleaning pin	For ø1.3 mm nozzle
	B1089	Cleaning pin	For ø1.6 mm nozzle
	B2875	Cleaning pin	For ø2.0, 2.3 mm nozzle

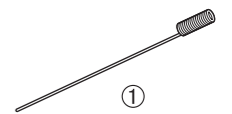

MEMO: